

Cod. SB0634B140AL6

Standard and Approvals

- Switch according to IEC/EN 60947-3
- Certified UL60947-4-1A and CAN/CSA C22.2 No. 60947-4-1-07
- Suitable as Manual Motor Controller

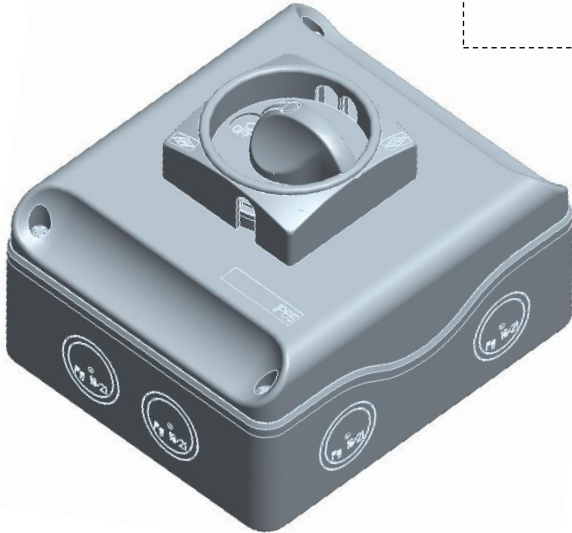

Technical characteristics

- ON-OFF 3+N
- ABS double insulation thermoplastic enclosure
- Rated operational current I_n : 63A
- Rated thermal current I_{th} : 63A
- Rating insulation voltage: 690V
- Positive opening double break contacts, silver alloy made
- Yellow plate 48x48mm and red padlockable knob (max. 3 padlocks)
- Switching angle: 90°
- Cover interlock in "ON" position
- Front drive
- IP65 Protection degree
- Fixing enclosure: 4 screw at 97x142mm



Plate and position

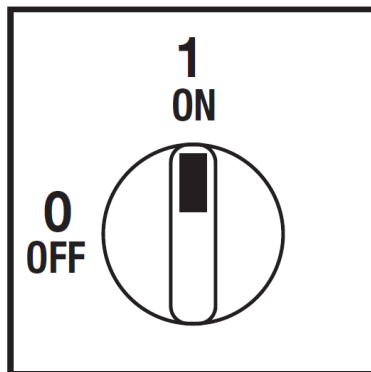

Electrical scheme

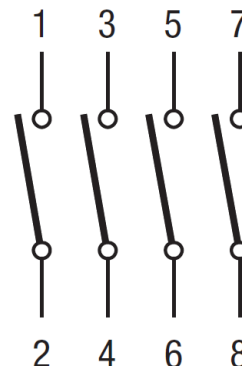

Cod. SB0634B140AL6

measures in mm (in)

Dimensions

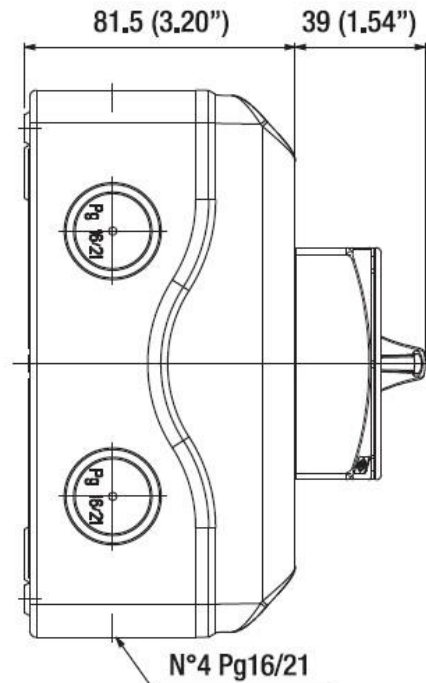
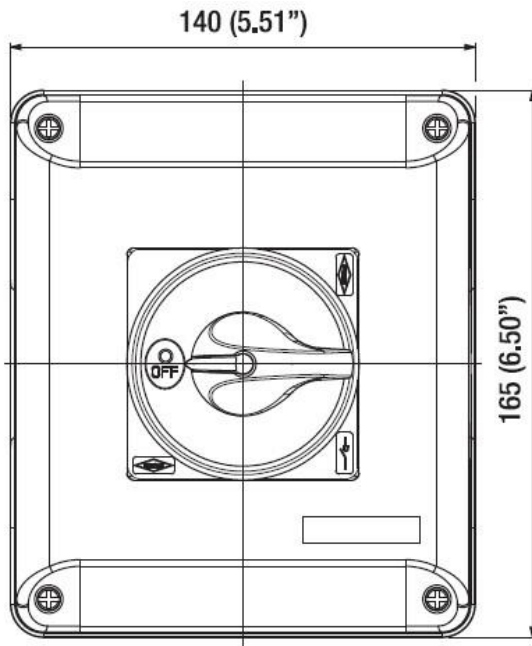

Drilling templates

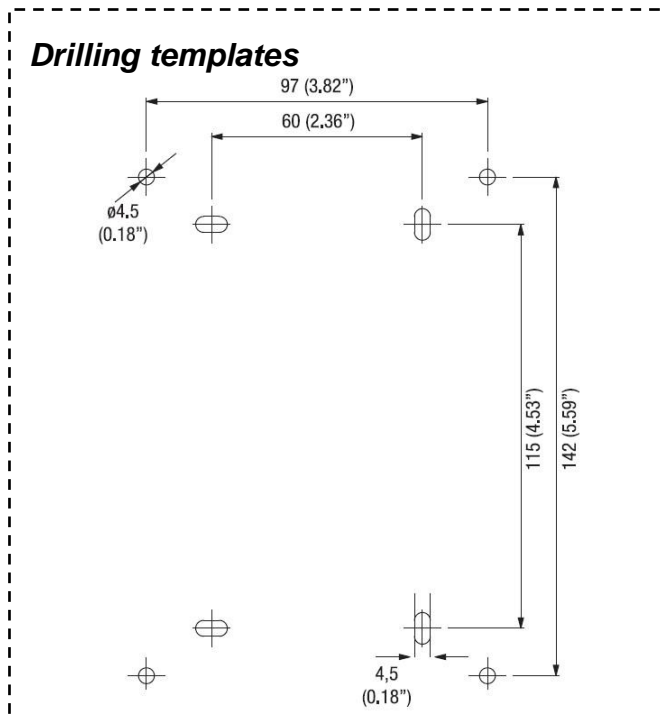

Cod. SB0634B140AL6

Technical data IEC 947-3 EN 60947-3			
Rated insulation voltage	Ui	V	690
Rated operating voltage	Ue	V	690
Rated impulse withstand voltage	Uimp	kV	6
Rated thermal current for open switch	Ith	A	63
Rated thermal current for enclosed switch	Ithe	A	63
Rated operation frequency		Hz	50
Power dissipation for each pole		W	3,7
Rated operating current Ie			
AC-21A Switching resistive loads, including moderate overloads	690V	Ie	A 63
AC-22A Switching of mixed resistive and inductive loads, including moderate overloads	690V	Ie	A 63
Rated operating power			
AC-23A Switching of motor loads or other highly inductive loads	400V	Kw (A)	25 (47)
	690V	Kw (A)	18,5 (19)
AC-3 Squirrel cage motors: starting, switching off motors during running	400V	Kw (A)	18,5 (33)
	690V	Kw (A)	15 (16)
Rated breaking capability in category AC-23A (cos φ=0,45)	400V	A	376
	690V	A	-
Short circuit protection			
Rated short time withstand current (1s)	Icw	A	1500
Rated short-circuit make capacity	Icm	A	2000
Rated conditional short-circuit current		kA	15
With fuses class gG	500V	A	63
Technical data UL/CSA (sec. UL508)			
General use voltage	Ue	V	600
General use current	600Vac	Ie	A 80
Rated operating power			
1 phase - 2 pole	120V	Hp/FLA	3/34
	240V	Hp/FLA	5/28
	200V	Hp/FLA	10/32
3 phase - 3 pole	240V	Hp/FLA	20/54
	480V	Hp/FLA	25/34
	600V	Hp/FLA	30/32
Line protection fuses (DS size 1: Class RK5, 600Vac, 200kA A.I.C.), (DS size 2: Class J, 600Vac)		A	225
Short Circuit Rating@600Vac		kA	10
Mechanical characteristics			
Mechanical life (120 cycles/hour)		Operations x10 ⁶	0,1
Connecting capability with flexible wires	Min-Max	mm ²	6-35
Connecting capability with solid wires	Min-Max	mm ²	10-50
Connecting capability with flexible wires	Min-Max	AWG	10/01
Connecting capability with solid wires	Min-Max	AWG	08/01
Terminal screw			M5
Screw tightening torque		Nm	2,8
		lbf-in	24
Protection degree IEC 529 EN 60529			
Terminals			IP20
Handles			IP66
Ambient conditions			
Operational ambient temperature		°C	-25 ÷ +70
Storage ambient temperature		°C	-40 ÷ +85
Withstand to constant humid according to IEC 60068			sec. IEC 60068-2-78
Withstand to cycling humid according to IEC 60069			90% at 55°C