

Cod. CA2000006PL4

Standard and Approvals

- Switch according to IEC/EN 60947-3
- Certified UL508
- Suitable as Manual Motor Controller

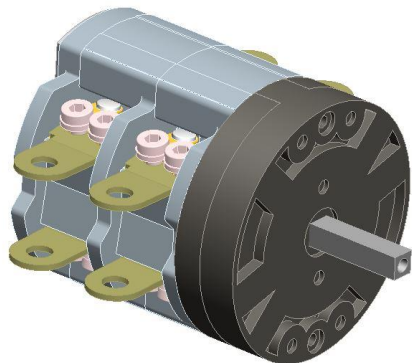

(Purely indicative image)



Technical characteristics: Body

- IP00 Protection degree
- Rated operational current Ie: 160A
- Rated thermal current Ith: 200A
- Rated insulation voltage Ui: 690V
- Rear Mounting
- Fixing with 4 screw at 30x90mm
- Switching angle: 60°
- Body in thermosetting material
- Assembled with metal shaft and threaded stud bolts to ensure maximum operating reliability
- Positive opening double break contacts, silver alloy made.

Technical characteristics: Knob

- Transparent plate 130x130mm and black knob
- IP40 Protection degree
- Fixing with 4 screws at 30x90mm

Positions

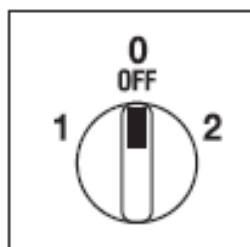

Electrical diagram

	2		X		X				
	0								
	1	X		X					
Contatto		1	2	3	4	5	6	7	8
Elemento		1				2			

Electrical function

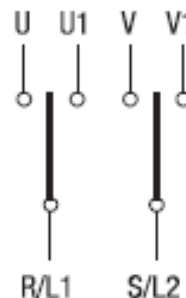

Cod. CA2000006PL4

Dimensions

measures in mm (in)

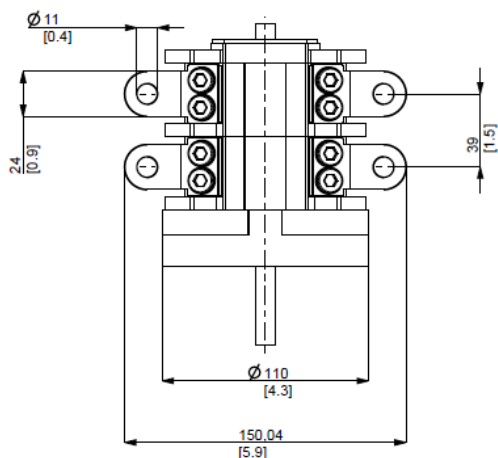
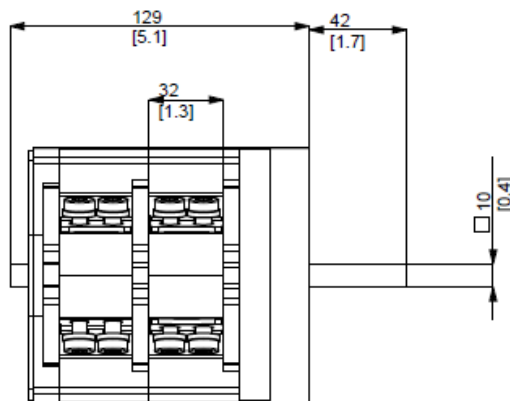
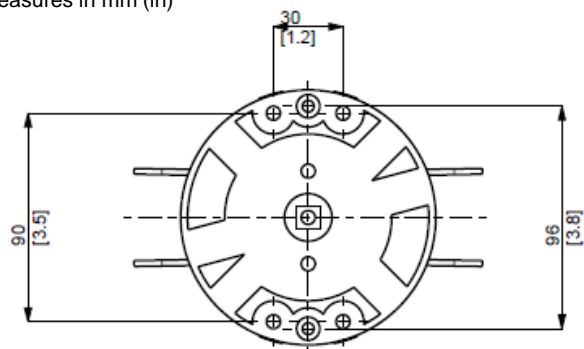

Drilling template

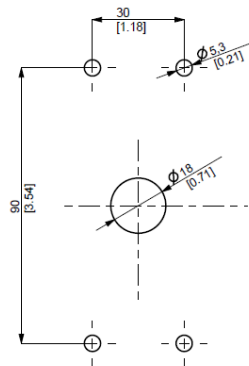

FISSAGGIO ANTERIORE
 FRONT MOUNTING

Plate & Knob

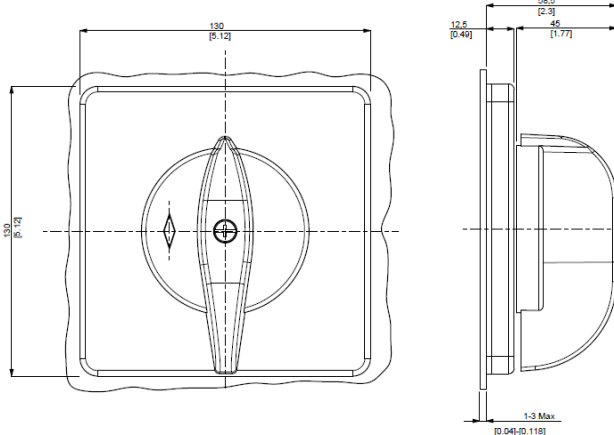

Cod. CA2000006PL4

Technical data IEC 947-3 EN 60947-3				
Rated insulation voltage	Ui	V		690
Rated operating voltage	Ue	V		690
Rated impulse withstand voltage	Uimp	kV		6
Rated thermal current for open switch	Ith	A		200
Rated thermal current for enclosed switch	Ithe	A		160
Rated operation frequency		Hz		50/60
Power dissipation for each pole		W		7
Rated operating current				
AC-21A Switching resistive loads, including moderate overloads	le	A		160 ⁵
AC-22A Switching of mixed resistive and inductive loads, including moderate overloads	le	A		160
AC-20A Connecting and disconnecting under no loads conditions				-
Rated operating power				
AC-23A Switching of motor loads or other highly inductive loads 3 phase - 3 pole	230V	Kw (A)		40 (125)
	400V	Kw (A)		59 (106)
	500V	Kw (A)		75 (108)
	690V	Kw (A)		-
AC-23A Switching of motor loads or other highly inductive loads 1 phase - 2 pole	110V	Kw (A)		11 (125)
	230V	Kw (A)		22 (120)
AC-3 Squirrel cage motors: starting, switching off motors during running 3 phase - 3 pole	230V	Kw (A)		30 (95)
	400V	Kw (A)		45 (82)
	500V	Kw (A)		59 (85)
	690V	Kw (A)		-
AC-3 Squirrel cage motors: starting, switching off motors during running 1 phase - 2 pole	110V	Kw (A)		9 (102)
	230V	Kw (A)		15 (82)
	400V	Kw (A)		-
AC-4 Squirrel cage motors: starting, pluggign, inching	230V	Kw (A)		-
	400V	Kw (A)		-
AC-15 Control of a.c electromagnetic loads	230V	A		-
	400V	A		-
Rated breaking capability in AC-23A (cos φ=0,45)	230V	A		1000
	400V	A		848
Short circuit protection				
Rated short time withstand current	Icw	A		2000
Rated short-circuit make capacity	Icm	A		3000
Rated conditional short-circuit current		kA		15
With fuses class gG	500V	A		200
Technical data UL/CSA				
Rated operating voltage	Ue	UL/CSA V		600/-
General use current	le	UL/CSA A		240/-
Short circuit rating @600Vac		Arms		-
Fuse size (Class RK5, 600Vac, 200kA A.I.C.)		A		-
Rated operating power				
1 phase - 2 pole	120V	Hp (A)		-
	240V	Hp (A)		-
3 phase - 3 pole	200V	Hp (A)		-
	240V	Hp (A)		-
	480V	Hp (A)		-
	600V	Hp (A)		-
Mechanical characteristics				
Mechanical life		Cycles x 10 ⁵		0,1
		Cycles/hr		120
Connection according to IEC 9471-1 and EN 50947-1				
Connecting capability	With flexible wires	Min-Max	mm ²	50-70 ¹
		Min-Max	AWG	1/0-2/0
	With solid wires	Min-Max	mm ²	16-35
Connection terminal screw dimensions		Type		M10
Screw tightening torque		Nm		23
Protection degree IEC 529 EN 60529				
Terminals		IP		00
Ambient conditions				
Operating ambient temperature		°C		-25 ÷ +55
Storage ambient temprature		°C		-30 ÷ +70
Withstand to constant humid according to IEC 60068				2-78
Withstand to cyclic humid according to IEC 60068				2-30

Note:

¹ = M10 bolt clamps with Nut

⁵ = a 500V