

1 2 3 4 5 6 7 8

A
B
C
D
E
F

A
B
C
D
E
F

QUESTO DISEGNO NON PUO' ESSERE
RIPRODOTTO NE MOSTRATO A TERZE
PERSONE ART.115-33 C.C.-289 C.P.

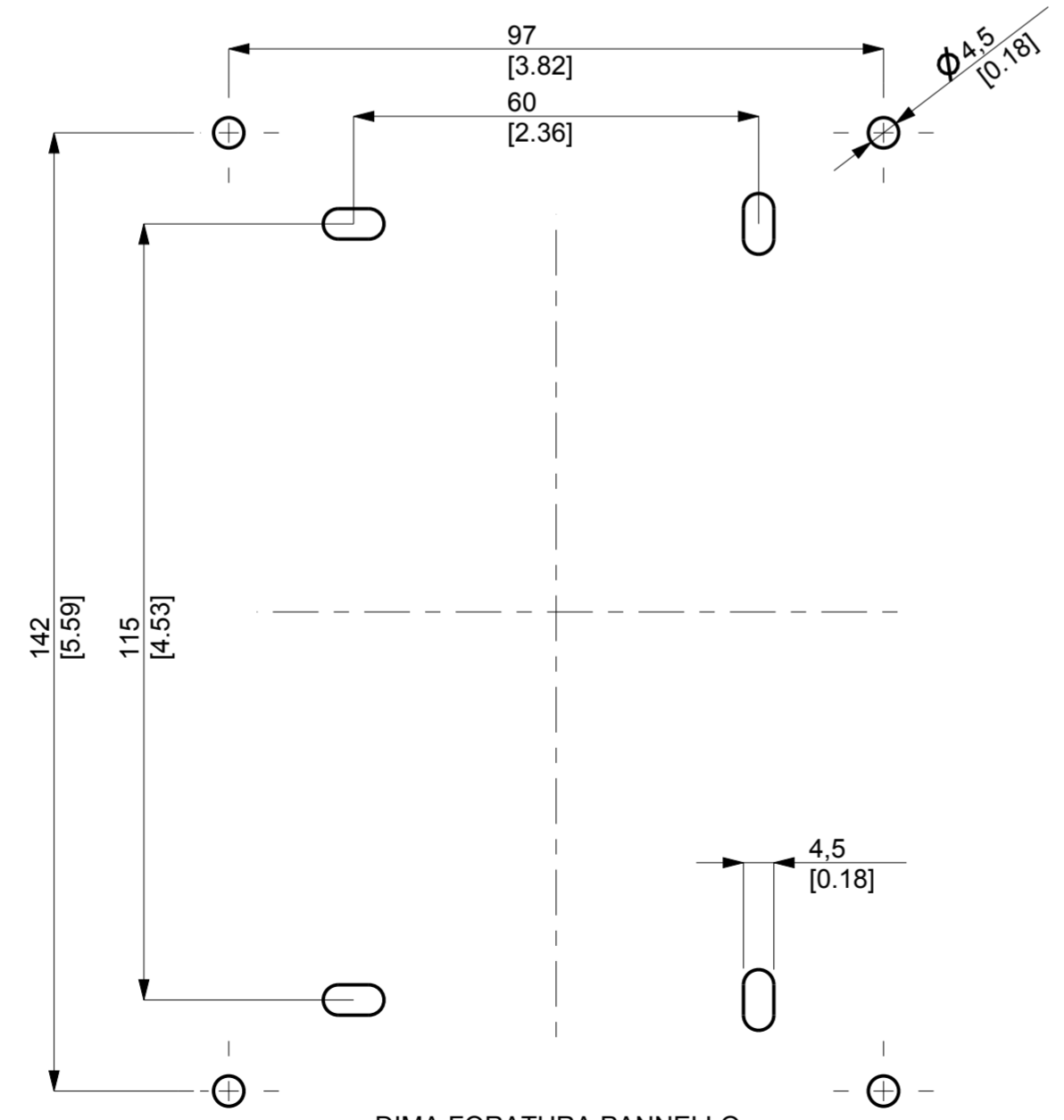
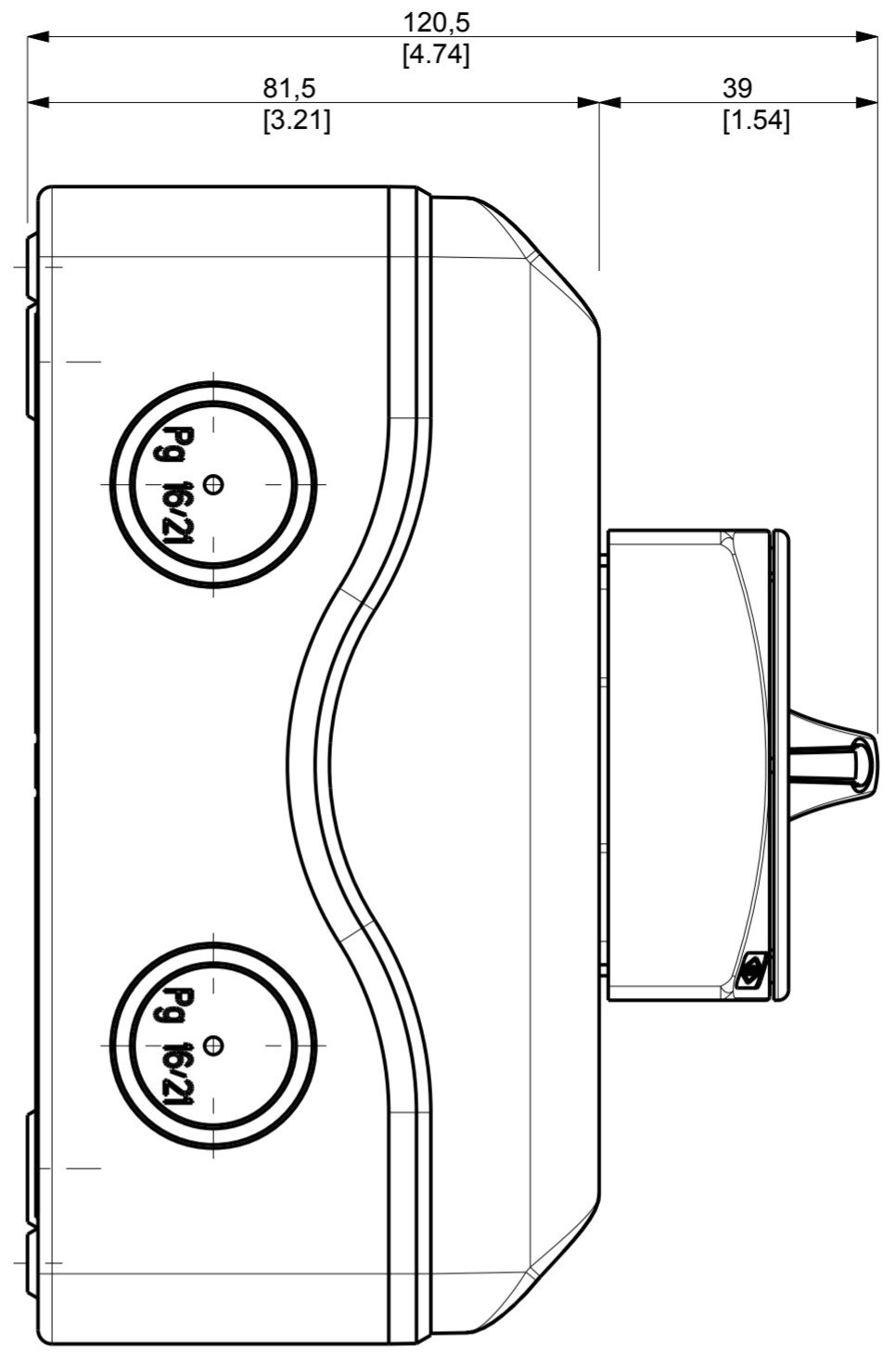
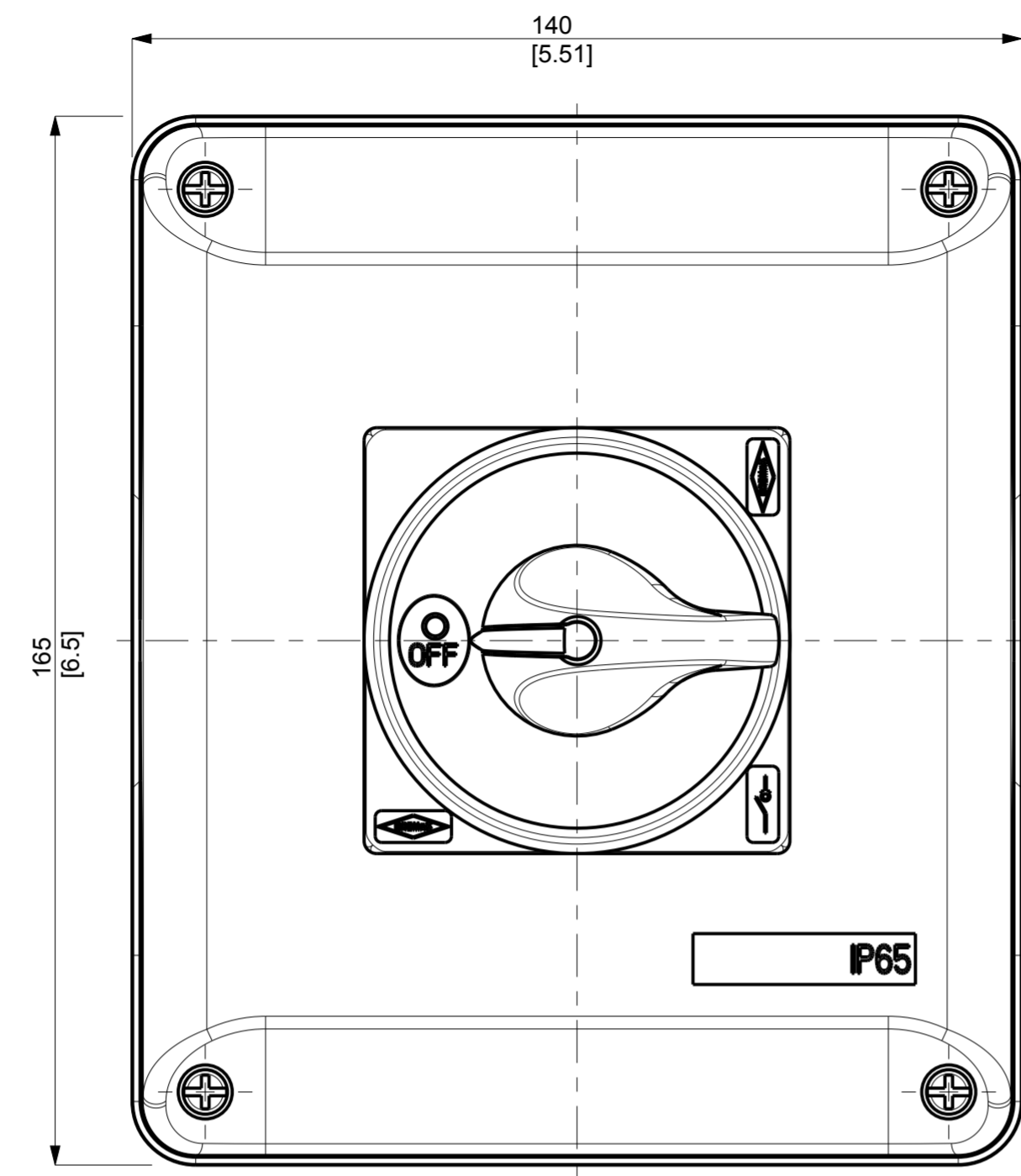

DIMA FORATURA PANNELLO
DRILLING TEMPLATE

Quote:[mm]
Measures:[in]

EDIZ./REL		MODIFICA / REVISION				DATA/DATE	SIGLA/SIGN
MATERIALE / MATERIAL: --		FINITURA / FINISHING: --					
	Dis/Drw: Cvettni	Impiego Use	Scala Scale	Toll. Gen. Gen. Tol.	Sost./Rep.the		
	Contr/Cxd	DS	1:1	Lineare/Linear	Sost./dal/Rep.of		
	Data/Date: 12-Nov-19			Angoli/Angles: 30°	Direttorio/Directory		
OGGETTO/OBJECT: SEZIONATORE SERIE DS50/100 3P IN CASSETTA B140					DISEGNO / DRAWING SB1003B140AL6		EDIZ./REL 1

QUESTO DISEGNO NON PUO' ESSERE
 RIPRODOTTO NE' MOSTRATO A TERZE
 PERSONE ART.115-33 C.C.-293 C.P.

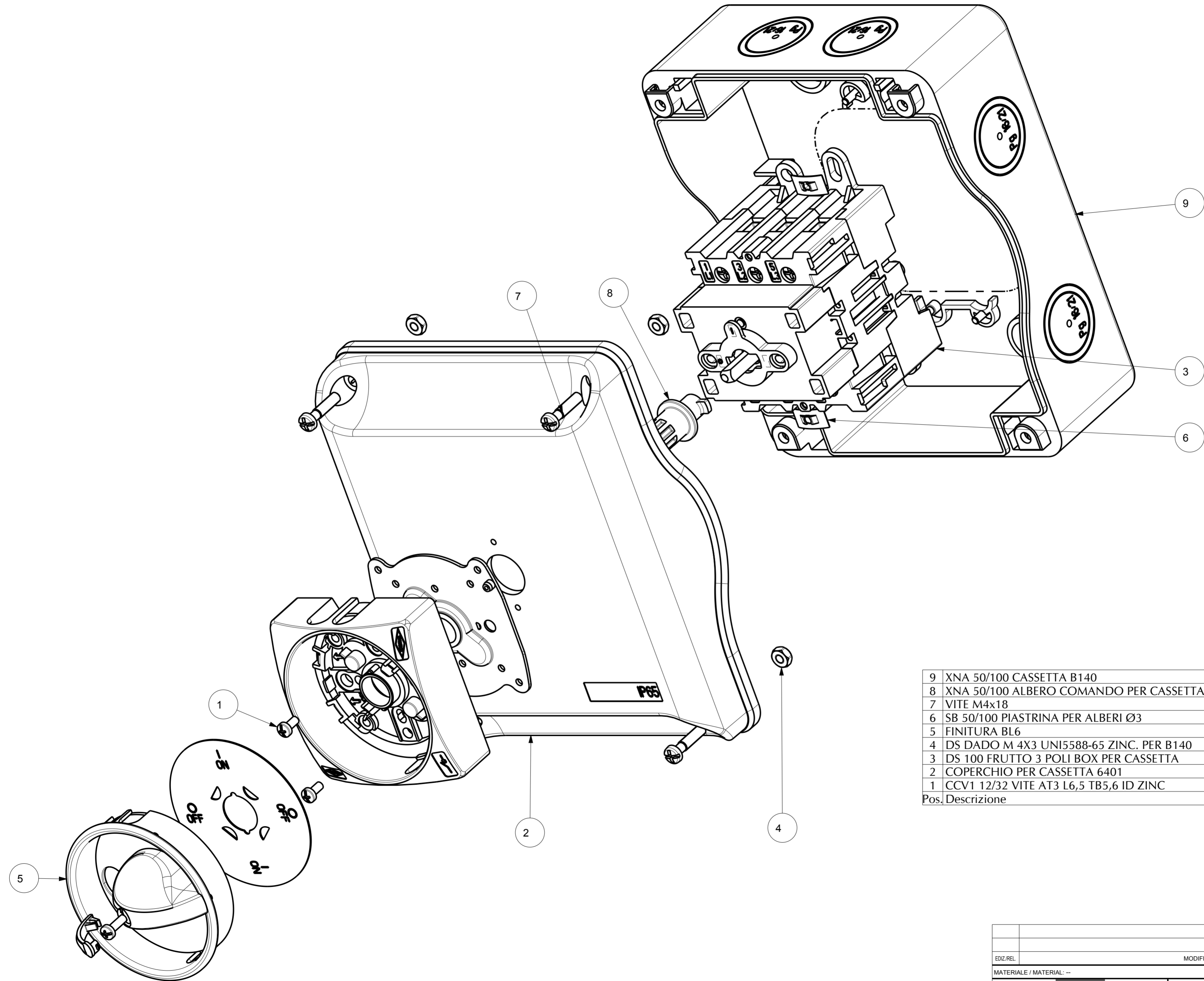

9	XNA 50/100 CASSETTA B140	6401_002	1
8	XNA 50/100 ALBERO COMANDO PER CASSETTA B140	6832_001	1
7	VITE M4x18	5122-022	4
6	SB 50/100 PIASTRINA PER ALBERI Ø3	7085	2
5	FINITURA BL6	VAG AL6_3D	1
4	DS DADO M 4X3 UNI5588-65 ZINC. PER B140	4901-005	4
3	DS 100 FRUTTO 3 POLI BOX PER CASSETTA	DS1003B140	1
2	COPERCHIO PER CASSETTA 6401	6402	1
1	CCV1 12/32 VITE AT3 L6,5 TB5,6 ID ZINC	6377_014	2
Pos.	Descrizione	Componente	Q.tà

EDIZ./REL		MODIFICA / REVISION				DATA/DATE	SIGLA/SIGN
MATERIALE / MATERIAL: --		FINITURA / FINISHING: --					
Dis/Drw/Mangiapane		Impiego Use	Scala Scale	Toll. Gen. Tol.	Sost./Rep.the		
Contr/Ckd		DS	1:1	Lineare/Linear Is12	Sost./dal/Rep.of		
Data/Date: 27-Feb-17				Angoli/Angles: ± 30'	Direttorio/Directory		
OGGETTO/OBJECT: SEZIONATORE SERIE DS50/100 3P IN CASSETTA B140						DISEGNO / DRAWING SB1003B140AL6	
						EDIZ./REL 1	