

QUESTO DISEGNO NON PUO' ESSERE
RIPRODOTTO NE MOSTRATO A TERZE
PERSONE ART. 115-33 C.C.-293 C.P.

PROHIBITION OF DISTRIBUTION AND
COPY. ART. 115-33 C.C.-293 C.P.

	mm		AWG	
	min	max	min ²	max
FLESSIBILE FLEXIBLE	1.5	10	16	8
RIGIDO SOLID	1.5	16	16	6

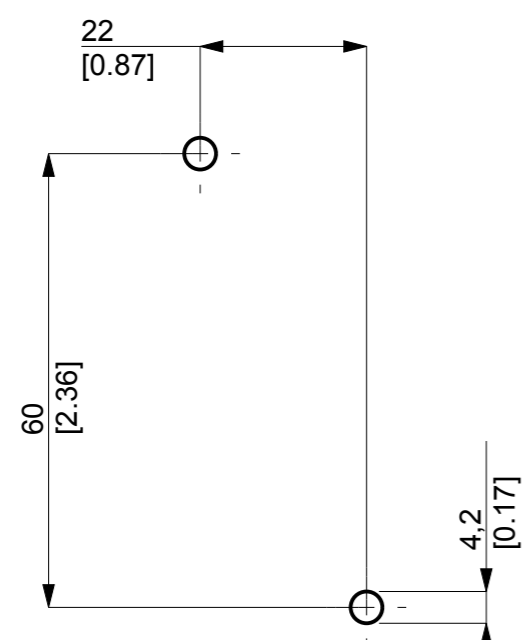
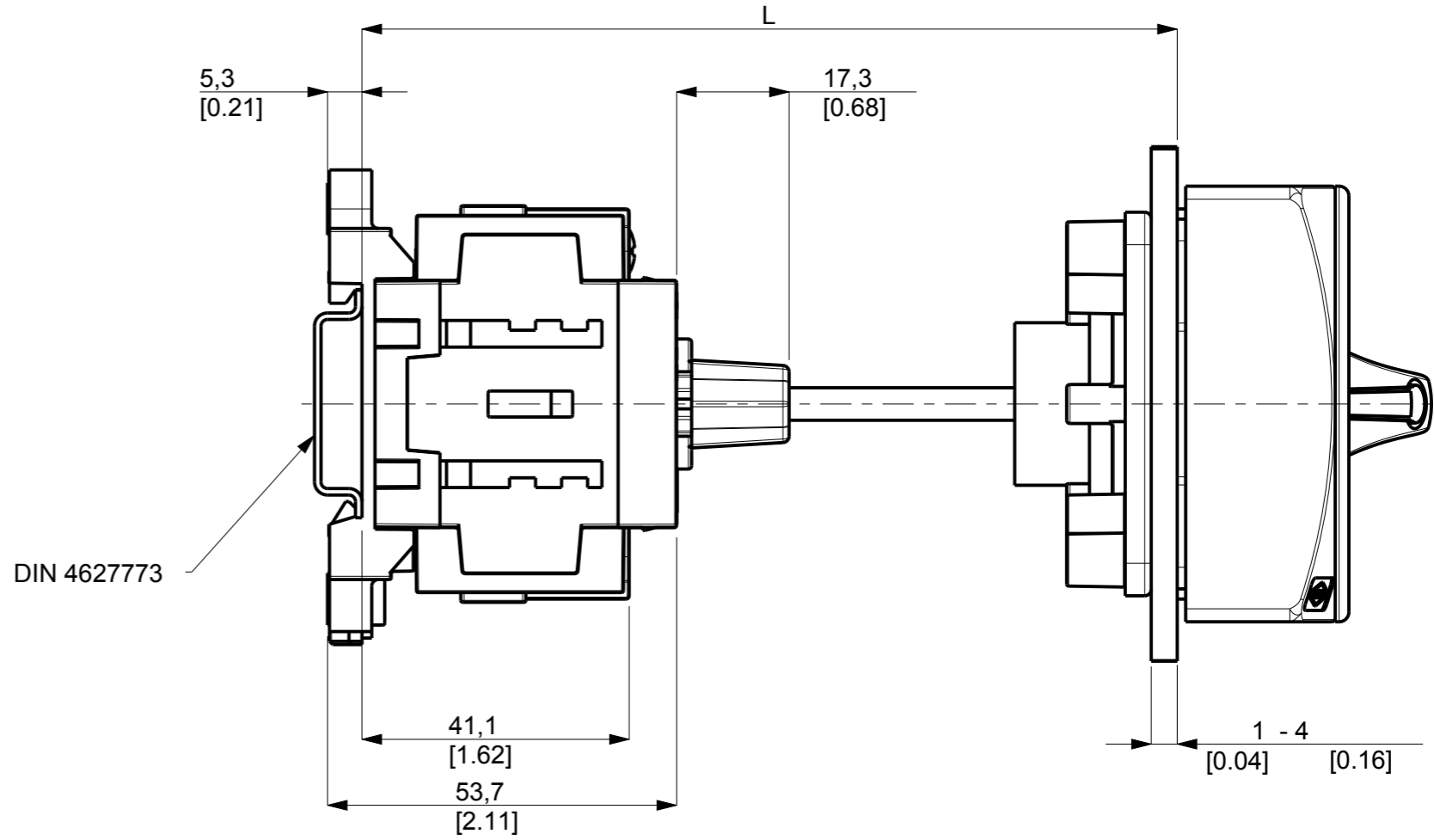
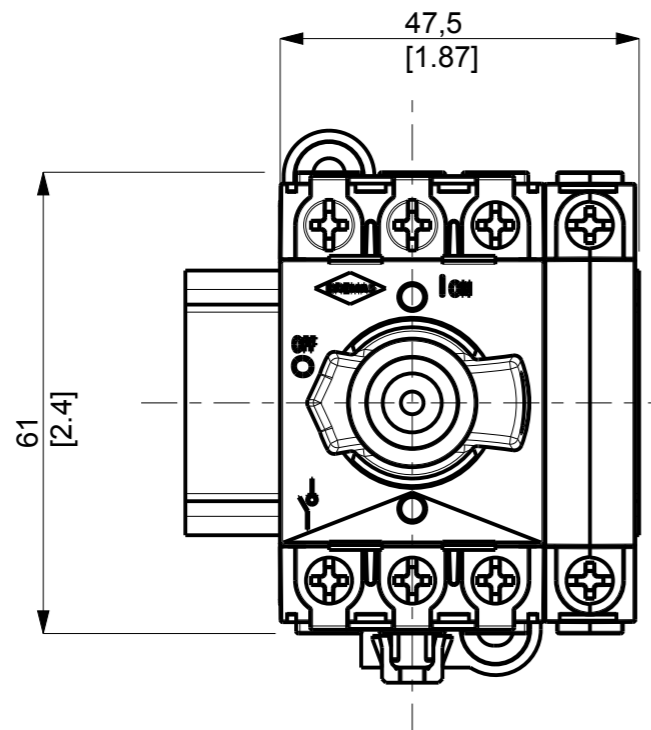

DIMA FORATURA PANNELLO
DRILLING TEMPLATE

Dimensioni in: mm[in]
Dimension in : mm [in]

L min.	L max.
92 [3.63]	227 [8.94]

2	AGGIORNATO DISEGNO	15-12-15	M.R.
EDIZ./REL.	MODIFICA / REVISION	DATA/DATE	SIGLA/SIGN
MATERIALE / MATERIAL: --		FINITURA / FINISHING: --	
	Dis/Dnw Mangiapane	Impiego Use	Scala Scale
	Contr/Ckd	--	1:1
	Data/Date: 01-Jul-14		Angoli/Angle: ± 30'
OGGETTO/OBJECT: SERIE DS020-032-040 B		DISEGNO / DRAWING DS324B_2D	
		EDIZ./REL 2	