

QUESTO DISEGNO NON PUO' ESSERE RIPRODOTTO NE MOSTRATO A TERZE PERSONE ART.115-33 C.C.-293 C.P.

PROHIBITION OF DISTRIBUTION AND COPY. ART.115-33 C.C.-293 C.P.

CAVI / WIRE				
	mm ²		AWG	
	min	max	min	max
FLESSIBILE FLEXIBLE	2x1.5	2x4	16	10
RIGIDO SOLID	2x1.5	2x6		

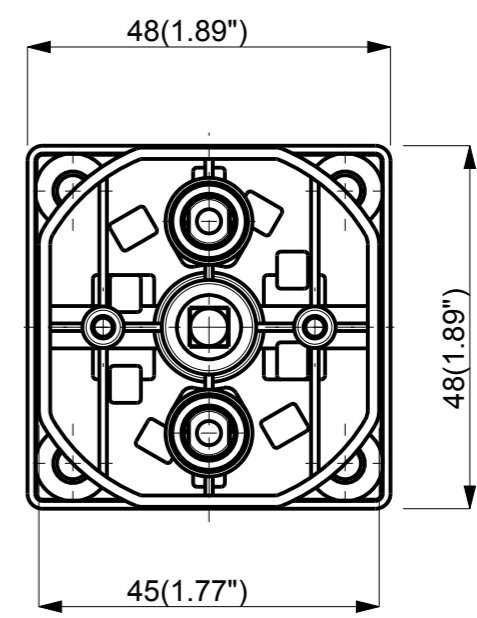
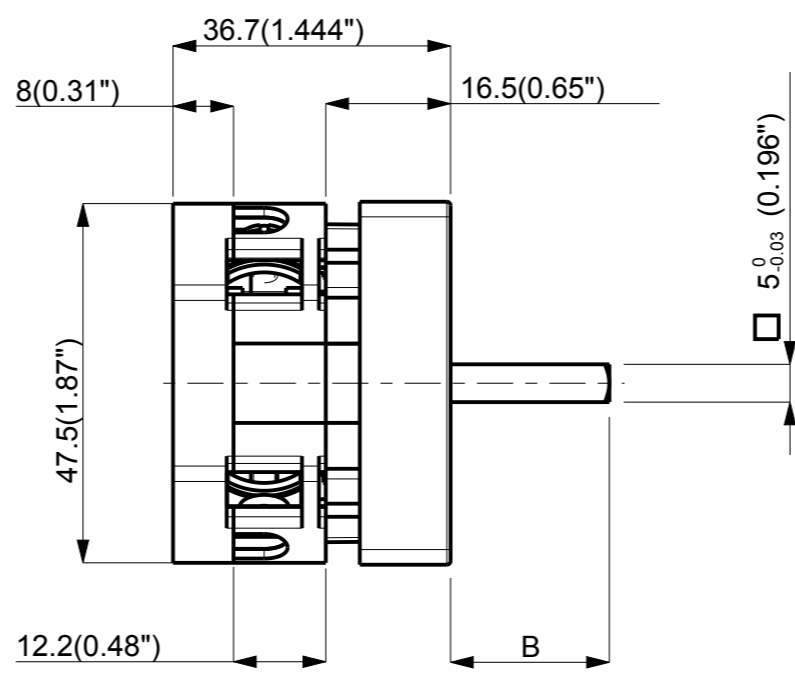
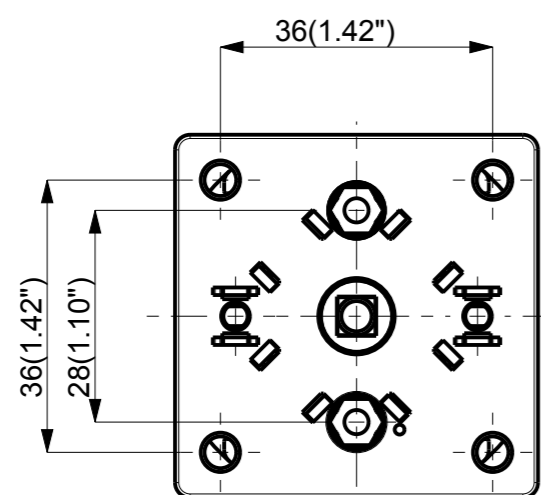

5⁰_{-0.03} (0.196")

B	
mm	inch
15	0.59
18	0.71
21	0.83
24	0.95

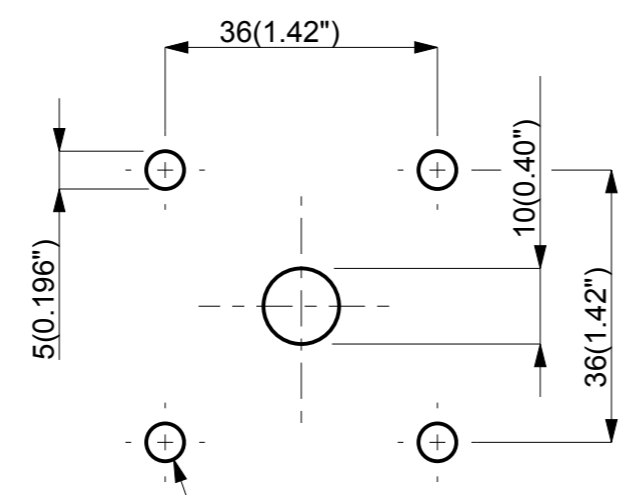
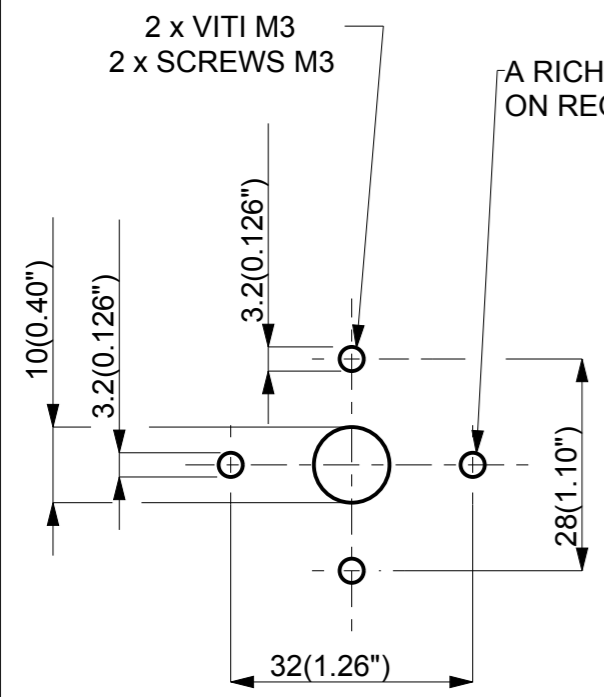

4 x VITI AUTOFORMANTI Ø 4.8
4 x THREAD FORMING SCREWS Ø 0.19"

DIMA FORATURA PANNELLO
DRILLING TEMPLATE

2	AGGIUNTO TABELLA CAVI, DIMA DI FORATURA, MISURE IN POLLICI	2-12-13	M.R.
EDIZ./REL.	MODIFICA / REVISION	DATA/DATE	SIGLA/SIGN
MATERIALE / MATERIAL: --		FINITURA / FINISHING: --	
 	Dis/Dnw Mangiapane	Impiego Use	Scala Scale
	Contr/Ckd	--	1:1
	Data/Date: 24-Oct-13		Angoli/Angle: ± 30'
OGGETTO/OBJECT: CRV2 12/26 N°1 ELEMENTO / ELEMENT		DISEGNO / DRAWING CRV2_12-26_1B	
		EDIZ./REL 2	